

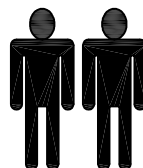

Cuba Futon Assembly Instructions

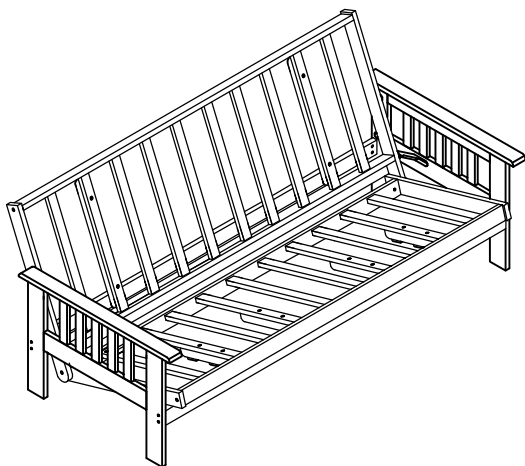

Use 2 people and assemble unit close to its final position

Assembly time: 1 hour approx.

SAFETY WARNING / CARE OF PRODUCTS

1. Before attempting to assemble or install this product, read and follow the instructions in this leaflet and on any attached labels!!

2. **NEVER ALLOW CHILDREN TO PLAY WITH OR OPERATE THE FOLD OUT BED**

ACTION.

3. **Routine maintenance :**

- Periodically check that all fixtures and connectors are tight.
- Check the bed action operates smoothly, maintaining the bed in the correct position.
- Check components for signs of damage.

4. Do not stand hot products directly on the wood surface.

5. Mop up any spills immediately.

6. Surface of wood is not resistant to bleaches, acids, or other "aggressive" agents.

7. Never use substitute parts. Always contact the supplier for replacement parts:

Kyoto Futons Ltd. Tel: 01778 380555 / Fax: 01778 380444

Before Starting Assembly

We suggest you spend a short time reading through this leaflet, then follow the simple step by step instructions





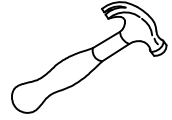
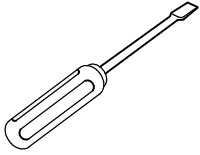

Some parts are viewed differently from exploded drawing shown; this is for extra clarity.

To avoid scratching, we advise that assembly takes place on a protected surface.

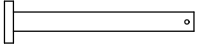
Do not discard any of the packaging, until you have checked all the parts and the pack of fittings.

FITTINGS & TOOLS

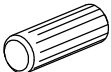

NO.	ITEM	QTY.	NO.	ITEM	QTY.
A	 60mm Bolt	16 pcs.	F	 Clevis Pin	2 pcs.
B	 30mm Bolt	12 pcs.	G	 Locking Pin	2 pcs.
C	 Barrel Nut	16 pcs.	<h2>COMPONENTS</h2>		
D	 Wood Dowel	20 pcs.			
E	 Plastic Washer	2 pcs.			

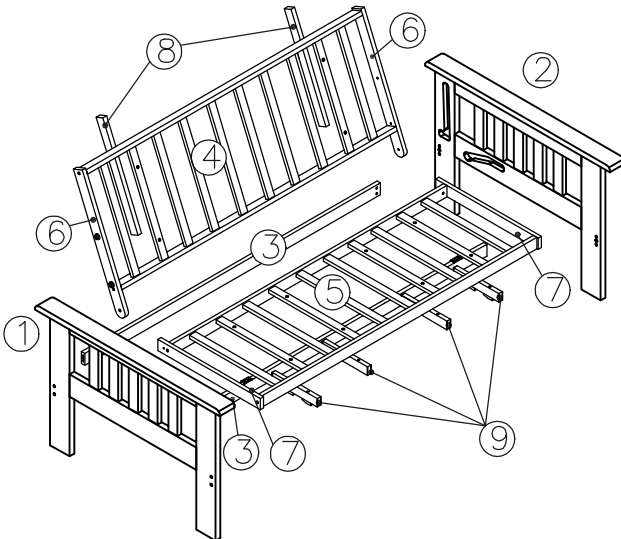

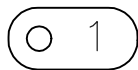

1



A x 8



C x 8 D x 4

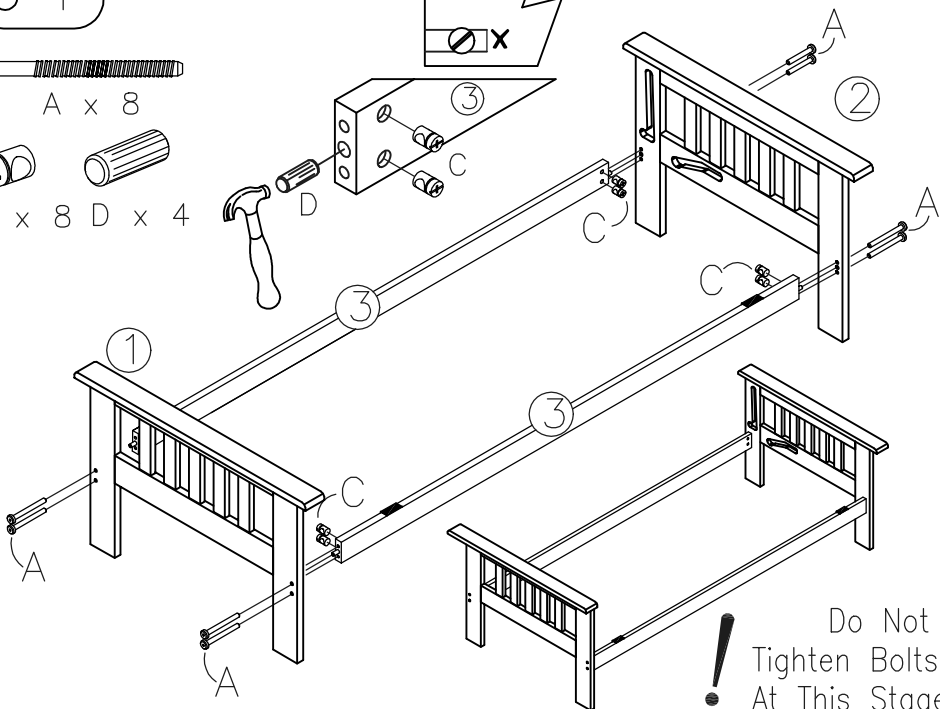
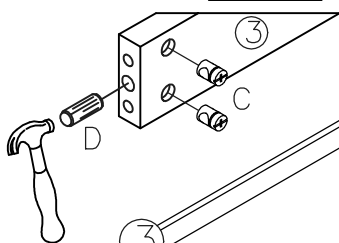
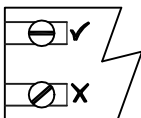

Do Not Tighten Bolts At This Stage

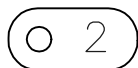

2

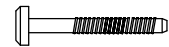

A x 8

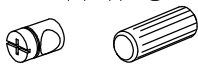

C x 8 D x 16

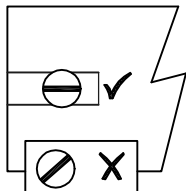
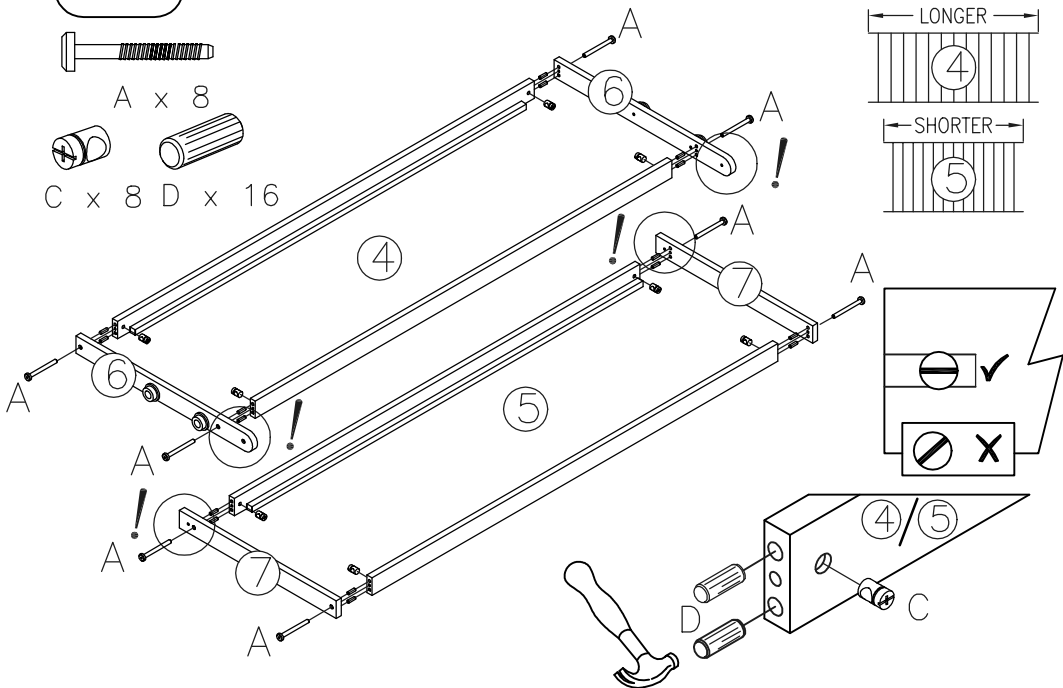
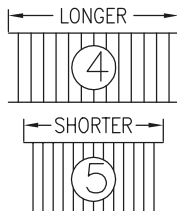

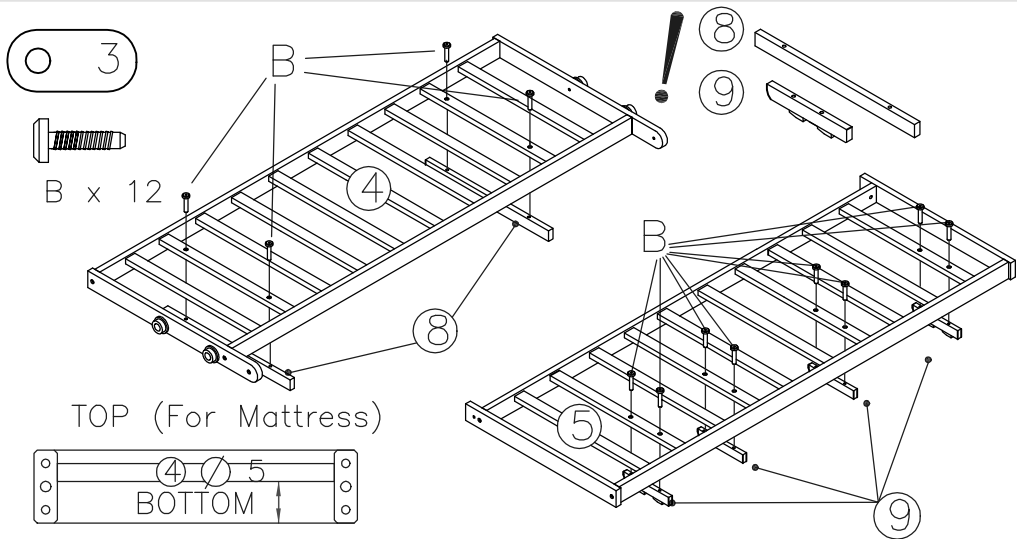

ATTENTION!
 Plastic Wheels
 can damage arm
 frames!!
 When back deck
 frame (4) is
 positioned,
TIGHTEN ALL
 frame bolts.

